

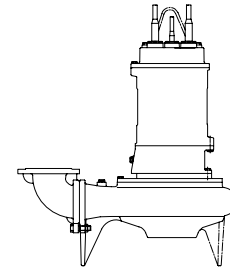

PRODUCT BULLETIN MODEL SSE SUBMERSIBLE SEWAGE

The SSE submersible sewage product has been designed to give you what you want, a durable submersible sewage pump, various impeller designs and high end motor features, all designed to give you long life. The pump features various impeller geometries designed to handle sewage and wastewater applications. The motor features an epoxy resin sealed cable base, an overload "Auto-Cut" motor protector and oil lubricated double mechanical seals.



Material Specifications

PART	CAST IRON FITTED
Casing	Cast Iron
Impeller	Cast Iron
Case Wear Ring	Cast Iron
Shaft	Stainless Steel
Motor Housing	Cast Iron
Bolts, Studs & Nuts	Satinless Steel
Mechanical Seal	Carbon/Ceramic Carbon/Si-Carbide

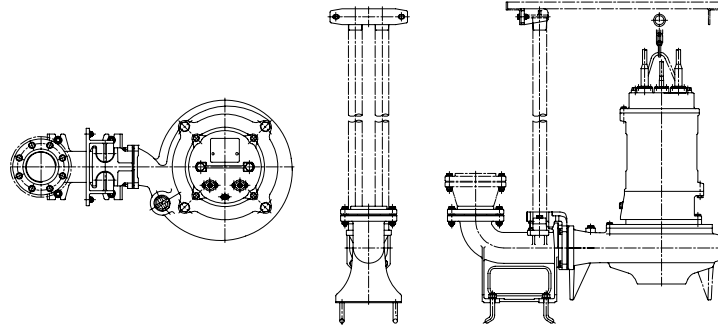

MODEL SSE SPECIFICATIONS

Casing: The casing is constructed of high tensile cast iron. It is of the volute type, carefully and accurately proportioned to permit smooth flow and to convert high velocity energy of the fluid as it leaves the impeller into pressure. Suction and discharge nozzles are cast integral with the volute. The casing has a vertical centerline discharge. Necessary vent and drain openings are provided.

Impeller: The impeller is of the single vane cutter or vortex type, casted in one piece of cast iron material. Single vane cutter style impellers feature a Tungsten-Carbide leading edge designed to cut through stringy solids in the pump fluid. Vortex style impellers create a vortex within the casing minimizing wear on the impeller which leads to increased life. All impellers are hydraulically and dynamically balanced prior to assembly and most impellers have pump out vanes standard on the back side of the impeller to reduce material from building up near the stuffing box.

Shaft: The shaft is of high strength 420 stainless steel, ground to accurate dimensions and polished to a smooth surface. It is designed for extra stiffness to avoid all critical speeds in operation.

Rear Cover: The rear cover is constructed of cast iron or other specified material. The rear cover houses the double mechanical seal which has a Carbon/Ceramic motor side and Carbon/Silicon-Carbide pump side face arrangement. Both mechanical seals are of the oil lubricated type to provide excellent lubricating fluid for the seal faces. All seal hardware is located in the oil lubricated seal housing, eliminating potential issues with foreign matter clogging the mechanical seal springs. An oil seal is located just outside of the seal chamber housing,

adding a third seal to the pump assembly, which eliminates large solid matter from contacting the outside seal face assembly.

Motor: The motor housing frame is constructed of high tensile cast iron and provides support for the windings, shaft and bearing housing. All American-Marsh submersible motors are air filled for ease in servicing, lower running temperatures and feature Class F insulation. Air filled motors have the advantage of being easier to service due to the fact that the large volume of oil required for operation is not present. Larger motor horsepower feature a cooling jacket on the motor housing, which lowers operating temperatures and extends motor life. These motors feature a motor overload design that protects the motor from high amperage draw, locked impeller and high temperature issues within the pumping assembly. The cable base of the motor has a compression fitting, an epoxy sealed housing, stripped back motor leads (to prevent wicking of moisture) and o-ring construction to prohibit moisture from entering the motor housing. On larger horsepower frame sizes, a moisture leakage detector is included standard for ultimate protection.

Easy Lift GRS (Guide Rail System): American-Marsh's Easy Lift GRS (Guide Rail System) allows the user to easily and efficiently remove and re-install a SBF Submersible Sewage Pump. The Easy Lift GRS consists of a discharge elbow, pump discharge coupling, two rails (not supplied) and a stainless steel lifting chain. The Easy Lift GRS is a must for quickly servicing the pump and motor assembly.

INDUSTRIAL
 Process Solids, Industrial Waste
COMMERCIAL
 Building Waste, Residential, Storm Water
MUNICIPAL
 Submersible Sewage, Heavy Solids
PRODUCT BULLETIN
MODEL SSE SUBMERSIBLE
SEWAGE

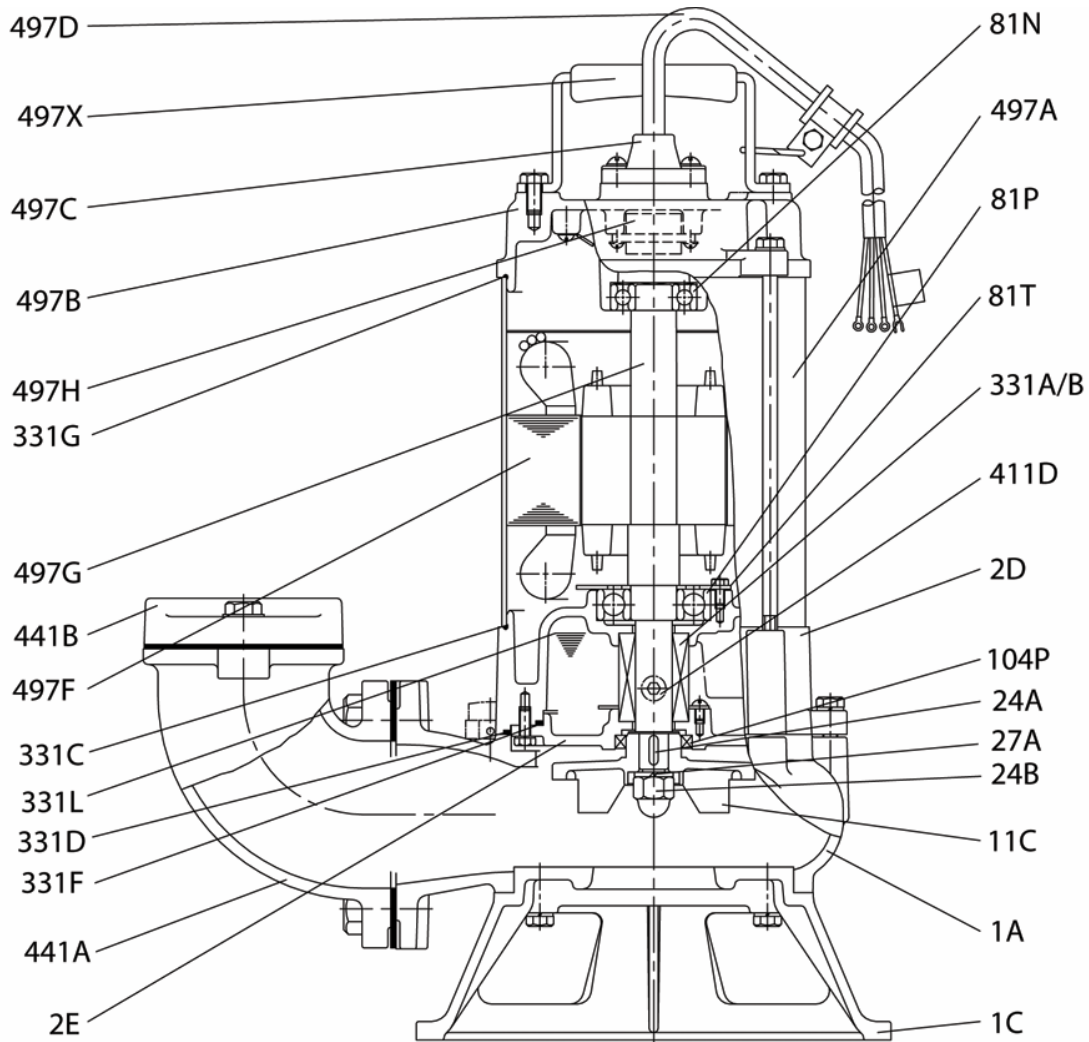

SSE Sectional Drawing

Item Number	Item Description	Num. Req.
1A	Casing	1
1C	Casing Cover	1
2D	Mechanical Seal Bracket	1
2E	Bearing Bracket	1
11C	Impeller	1
24A	Impeller Key	1
24B	Impeller Locknut	1
27A	Impeller Lockwasher	1
81N	Outboard Bearing	1
81P	Inboard Bearing	1
81T	Inboard Bearing Thrust Plate	1
104P	Oil Lip Seal	1
331A	Mechanical Seal (Motor Side)	1
331B	Mechanical Seal (Pump Side)	1
331C	Motor Housing O-Ring	1
331D	Mechanical Seal Bracket O-Ring	1
331F	Casing O-Ring	1
331G	Upper Housing Cover O-Ring	1

Item Number	Item Description	Num. Req.
331L	Mechanical Seal Lubricant	1
331M	Upper Housing Cover O-Ring	1
331N	Motor Lead Base O-Ring	1
331X	Mechanical Seal Moisture Sensor	1
331XC	Mech. Seal Moisture Cable Base	1
331XD	Mech. Seal Moisture Sensor Cable	1
411D	Oil Plug	2
441A	Discharge Elbow	1
441B	Companion Flange	1
497A	Motor Housing	1
497B	Upper Housing Cover	1
497C	Motor Lead Base Cover	1
497D	Motor Lead	1
497F	Stator	1
497G	Shaft (with Rotor)	1
497H	Motor Overload Protection	1
497X	Stainless Steel Eyehook	Varies

Recommended spare parts are in **BOLD**.